

DEUTZ BFM 1013

For mobile machinery ■ 92 - 223 kW | 123 - 299 hp at 2000 - 2300 min⁻¹ | rpm ■ EU stage II / US EPA Tier 2

- Water-cooled 4 and 6-cylinder inline engines with turbocharging and charge air cooling
- The robust engine design allows worldwide operation even with high sulphur fuels.
- The compact engine design and three PTO drive possibilities integrated into the gear drive reduce the installation cost and increase the number of applications.
- Best cold starting performance even under extreme conditions.
- Low noise emissions due to acoustically optimized components with very smooth running and high durability.
- Wet cylinder liners, long oil change intervals and easy changing of the engine fluids reduce the running and service cost and increase the availability of the machinery.
- Also available with an electronic motor regulator (EMR) to allow easy integration into the electronic device control and monitoring system.

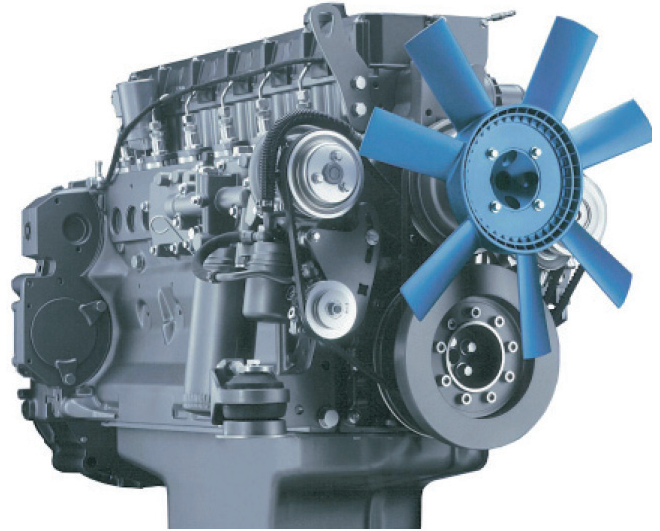

TECHNICAL DATA

| Engine Type | | BF4M1013EC | BF4M1013FC | BF6M1013EC | BF6M1013FC |
|-----------------------|-------------------------|-------------------|-------------------|-------------------|-------------------|
| No. of cylinders | | 4 | 4 | 6 | 6 |
| Bore/stroke | mm in | 108/130 4.3/5.1 | 108/130 4.3/5.1 | 108/130 4.3/5.1 | 108/130 4.3/5.1 |
| Displacement | l cu in | 4.8 292.9 | 4.8 292.9 | 7.2 439.4 | 7.2 439.4 |
| Maximum nominal speed | min ⁻¹ rpm | 2300 | 2300 | 2300 | 2300 |

| Engine Type | | BF4M1013EC | BF4M1013FC | BF6M1013EC | BF6M1013FC |
|---|-------------------------|-------------|-------------|-------------|---------------------------------|
| Power output as per ISO 14396 | kW hp | 118 158 | 118 158 | 174 233 | 200/223 ⁴⁾ 268/299 |
| at speed | min ⁻¹ rpm | 2300 | 2300 | 2300 | 2300 |
| Max. torque | Nm lb/ft | 577 426 | 700 516 | 854 630 | 1050 774 |
| at speed | min ⁻¹ rpm | 1400 | 1400 | 1400 | 1400 |
| Minimum idling speed | min ⁻¹ rpm | 650 | 650 | 650 | 650 |
| Specific fuel consumption ²⁾ | g/kWh lb/hph | 205 0.337 | 204 0.335 | 205 0.337 | 195 0.321 |
| Weight as per DIN 70020 Part 7A ³⁾ | kg lb | 432 952 | 432 952 | 572 1261 | 572 1261 |

1) Power data without deduction of fan power.

2) Best full load consumption refers to diesel with a density of 0.835 kg/dm³ at 15°C | 6.96 lb/US gallon at 60°F.

3) Without starter/alternator, cooler and fluids but with flywheel and flywheel housing.

4) Exceptional output.

CHARACTERISTIC CURVES

BF4M 1013 EC - 118 kW
BF4M 1013 FC - 129 kW

BF6M 1013 EC - 174 kW
BF6M 1013 FC - 200 kW / BF6M 1013 FC - 223 kW

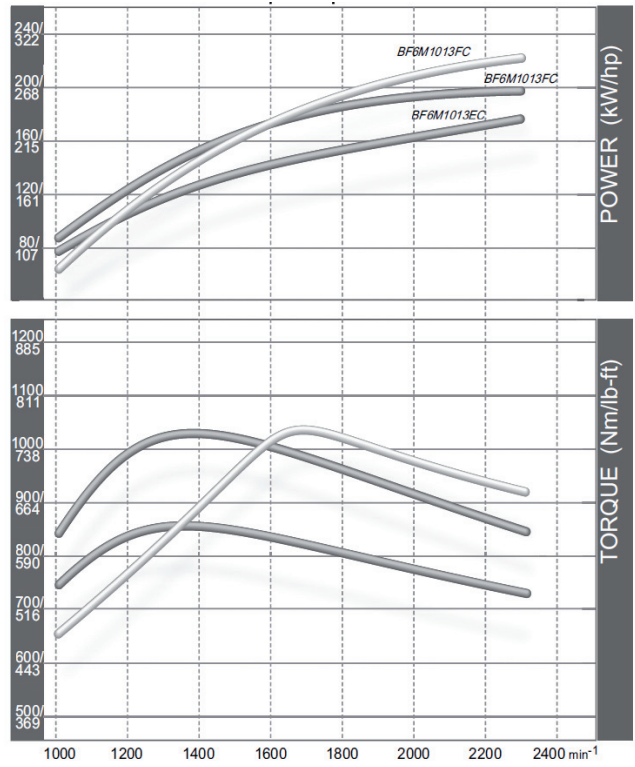
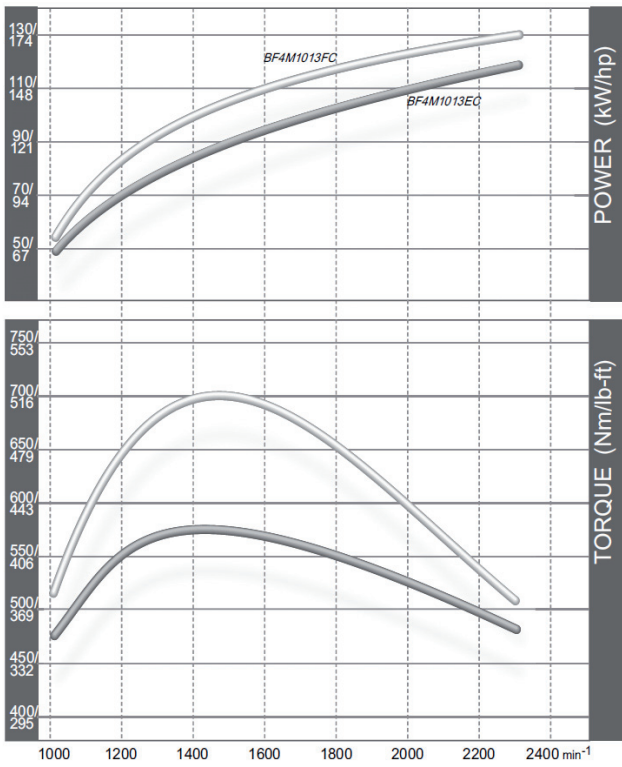

DIMENSIONS

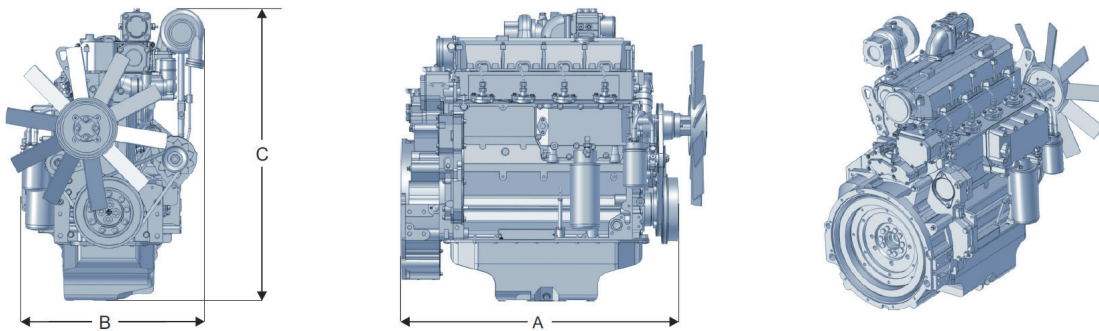

| Engine Type | | A | B | C |
|-------------------|---------|-------------|------------|----------|
| BF4M 1013 EC / FC | mm in | 895 35.2 | 634 25 | 940 37 |
| BF6M 1013 EC / FC | mm in | 1162 45.7 | 683 26.9 | 990 39 |

Note: Preliminary technical data. The engine dimensions and weights vary depending on the scope of delivery.

The data on this data sheet are for information purposes only and are not binding values. For more information please contact your responsible sales partner.

DEUTZ AG
Ottostraße 1
51149 Cologne, Germany
Phone: +49 (0) 221 822-0
Telefax: +49 (0) 221 822-3525
E-Mail: info@deutz.com
www.facebook.com/deutzofficial
www.deutz.com

The engine company. 